

START HERE!

READ ME FIRST

Don't be a hero and muscle through this installation without reading these fitting instructions first! Improper installation of this gear may void certain aspects of your warranty.

Before you begin, take a moment and open all your Front Runner rack kit boxes and gather the assembly instructions for the various components.

A complete kit will contain:

1. A Front Runner Mounting System specific to your vehicle
2. A Front Runner Rack Tray or Load Bar Slats

This document will guide you through the assembly of the mounting system and assist you in fitting the roof rack tray or load bars to your specific vehicle.

Please refer to the next page for a list of all the components, quantities and tools required.

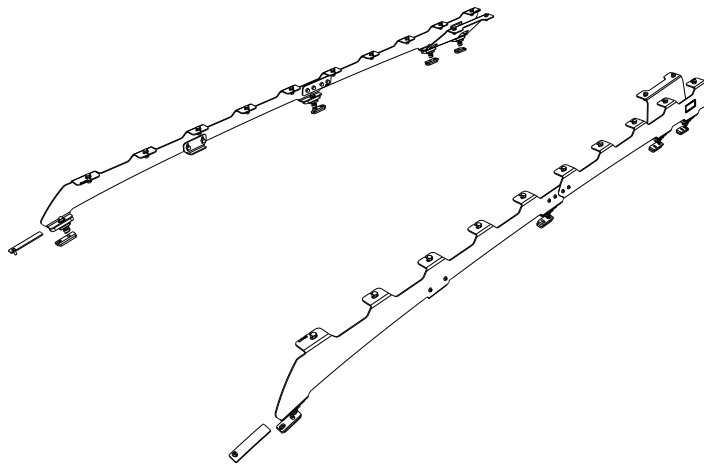

IMPORTANT WARNING!

IT IS CRITICAL THAT ALL FRONT RUNNER PRODUCTS BE PROPERLY AND SECURELY ASSEMBLED AND ATTACHED TO YOUR VEHICLE. IMPROPER ATTACHMENT COULD RESULT IN AN AUTOMOBILE ACCIDENT, AND COULD CAUSE SERIOUS BODILY INJURY OR DEATH. YOU ARE RESPONSIBLE FOR ASSEMBLING AND SECURING ALL FRONT RUNNER PRODUCTS TO YOUR VEHICLE, CHECKING THE ATTACHMENTS PRIOR TO USE, AND PERIODICALLY INSPECTING THE PRODUCTS FOR ADJUSTMENT, WEAR AND DAMAGE. THEREFORE, YOU MUST READ AND UNDERSTAND ALL OF THE INSTRUCTIONS AND PRECAUTIONS SUPPLIED WITH YOUR FRONT RUNNER PRODUCT PRIOR TO INSTALLATION OR USE. IF YOU DO NOT UNDERSTAND ALL OF THE INSTRUCTIONS AND CAUTIONS, OR IF YOU HAVE NO MECHANICAL EXPERIENCE AND ARE NOT THOROUGHLY FAMILIAR WITH THE INSTALLATION PROCEDURES, YOU SHOULD HAVE THE PRODUCT INSTALLED BY A PROFESSIONAL INSTALLER OR OTHER QUALIFIED PERSONNEL.

NOTE: Front Runner will not be responsible for any damage caused by the failure to install the product according to these instructions.

Please call us if you have any questions about the installation of this product.



1 GET ORGANIZED

IN THE BOX

1	2 X	Front Foot Rail LH & RH
2	2 X	Rear Foot Rail LH & RH
3	2 X	Joiner Plate
4	14 X	M6 X 16 Button Head Screw
5	12 X	M6 Nyloc Nut
6	8 X	Spacer 10mm
7	24 X	M8 X 20 Hex Bolt
8	24 X	M8 X 16 X 1.6 Flat Washer
9	24 X	M8 Nyloc Nut
10	24 X	M8 Nut Cap
11	8 X	M6 X 20 X 2 Flat Washer
12	8 X	M6 X 35 Hex Bolt
14	20 X	M6 Nut Cap
15	2 X	Support Bracket

IN THE BOX

16	4 X	M6 X 12 X 1 Flat Washer
17	2 X	Cover Plate
18	10 X	Spacer - FAFE002_017
19	2 X	Spacer - FAFE002_021
20	4 X	Spacer - FAFE002_018
21	2 X	Spacer - FAFE002_020
23	8 X	M6 X 8 Button Head Screw
24	2 X	Support Bracket 1LH & 1RH

TOOLS NEEDED

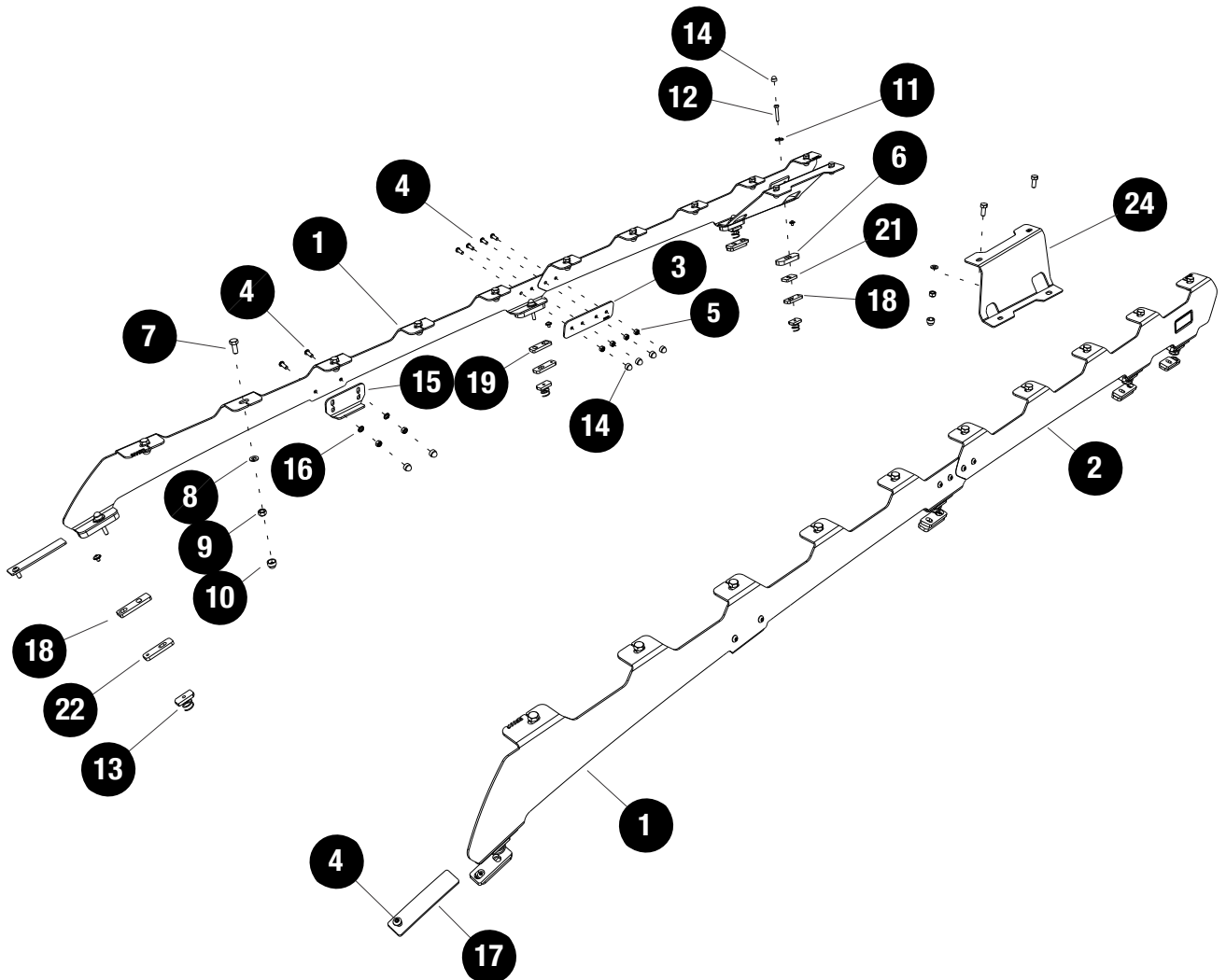

2

FIT AND SECURE

2.1

To achieve this installation you will need to remove the Interior roof lining and then the factory roof rails.



2.2

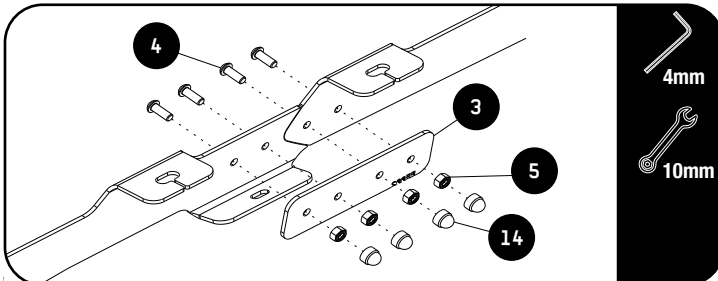

Join the two halves of the Foot Rails (Item 1 & 2) with the supplied Joiner plate (Item 3). Use the M6 x 16 Button Head bolt, M6 Nyloc Nut and M6 Nut Cap (Item 4, 5 & 14) and Fasten as shown.



Tightening Torque:

M6 : 8-10Nm / 5.9 ft lb - 7.38 ft lb

2.3

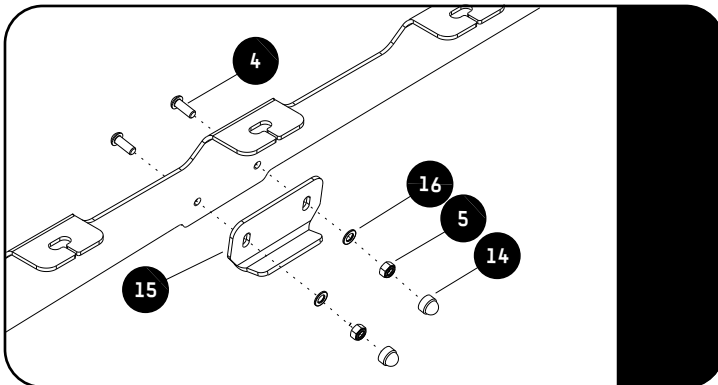

Loosely fit the Support Bracket (Item 15) to the foot rail using M6 x 16 Button Head Bolts, M6 Flat Washer and M6 Nyloc Nuts (Items 4, 5 & 16).

The Support Bracket will be fully secured once the foot rails are secured to the vehicle.

2.4

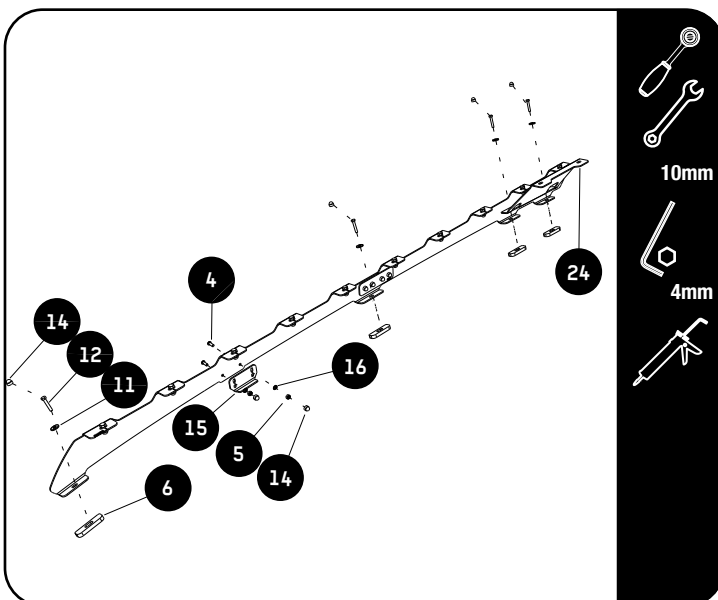

Apply a bead of silicone around each mounting hole in the roof.

Place Spacers (Item 6) over each of the mounting holes in the vehicle roof.

Apply a bead of silicone on each Hex Bolt before inserting it into the roof.

Place the Foot Rails onto the Spacers and secure using M6 x 35 Hex Bolts, M6 Washers and M6 Nut Plates (Items 11, 12 & 13) as shown.

Tip: Straighten the wire on the Nut Plate to assist in aligning it with the Hex Bolts.

Fully tighten all the fasteners.



Tightening Torque:

M6 : 8-10Nm / 5.9 ft lb - 7.38 ft lb

2.5

Tighten all the nuts and bolts securing the foot rails to the vehicle's roof. Place a M6 Nut Cap (Item 14) over each of the M6 Nuts and Hex Bolts.



10mm

3

FIT AND SECURE

3.1

FITMENT FOR THE FORD EVEREST PLATINUM 2023



3.2

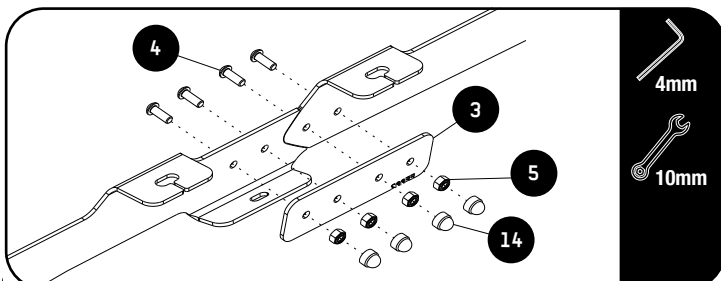

Join the two halves of the Foot Rails (Item 1 & 3) with the supplied Joiner plate (Item 3). Use the M6 x 16 Button Head bolt, M6 Nyloc Nut and M6 Nut Cap (Item 4, 5 & 14) and Fasten as shown.



Tightening Torque:

M6 : 8-10Nm / 5.9 ft lb - 7.38 ft lb

3.3

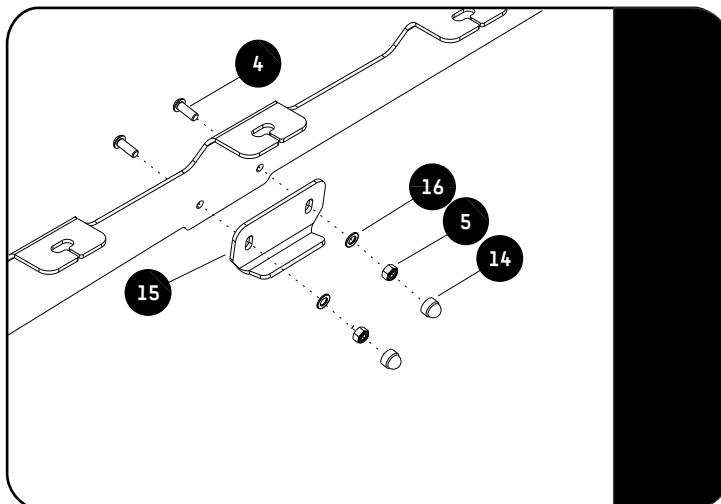

Loosely fit the Support Bracket (Item 15) to the foot rail using M6 x 16 Button Head Bolts, M6 Flat Washer and M6 Nyloc Nuts (Items 4, 5 & 16).

The Support Bracket will be fully secured once the foot rails are secured to the vehicle.

3.4

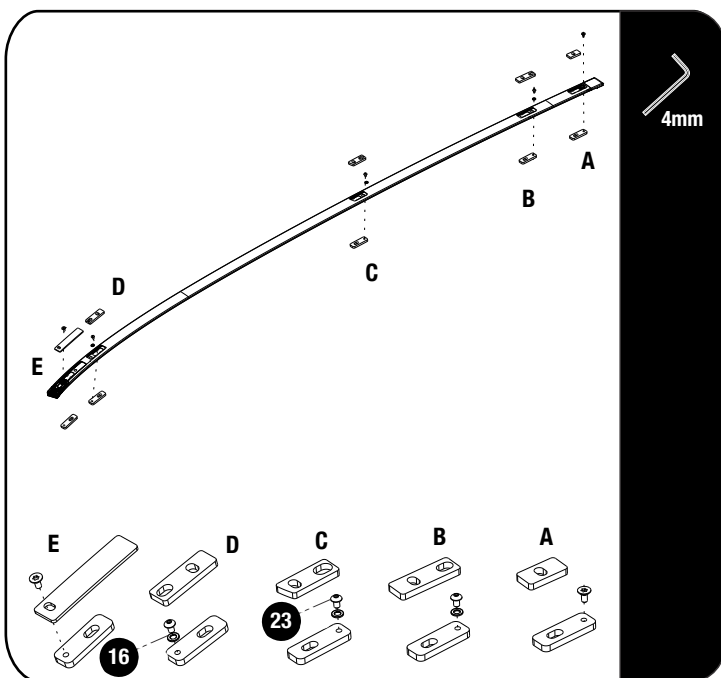

The Roof lining should be removed as in 2.1. With the OEM rails removed from the Vehicle there will be 5 openings in the Ditch mold.

Apply a bead of silicone around each mounting hole in the roof.

Place the spacers as shown starting from the back (A) using the M6 x 8 Button head bolt and M6 Flat washer.

Take note of the OEM screw used in the back and front (A & E) of the ditch mold.

Once all the spacers are in place, place the ditch mold back on the roof.

3

FIT AND SECURE

3.5

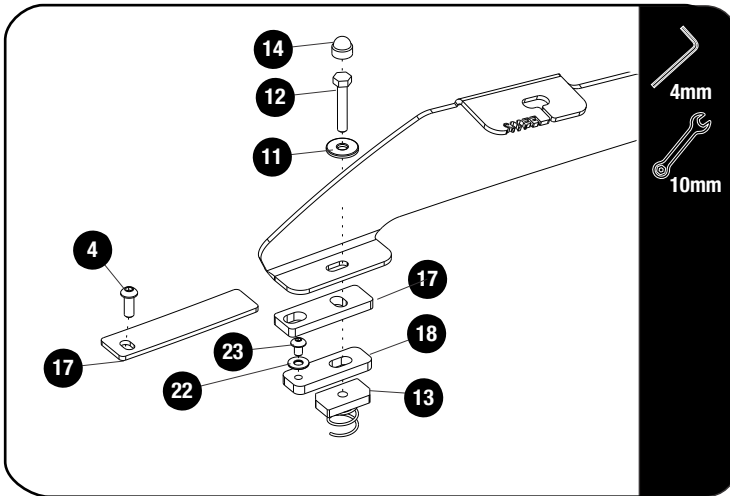

Apply a bead of silicone on each Hex Bolt inserting it into the roof.

Place the Foot Rails onto the Spacers and loosely secure using M6 x 35 Hex Bolts, M6 Washers and M6 Nut Plates (Items 11, 12 & 13) as shown.

Tip: Straighten the wire on the Nut Plate to assist in aligning it with the Hex Bolts.



Tightening Torque:

M6 : 8-10Nm / 5.9 ft lb - 7.38 ft lb

3.6

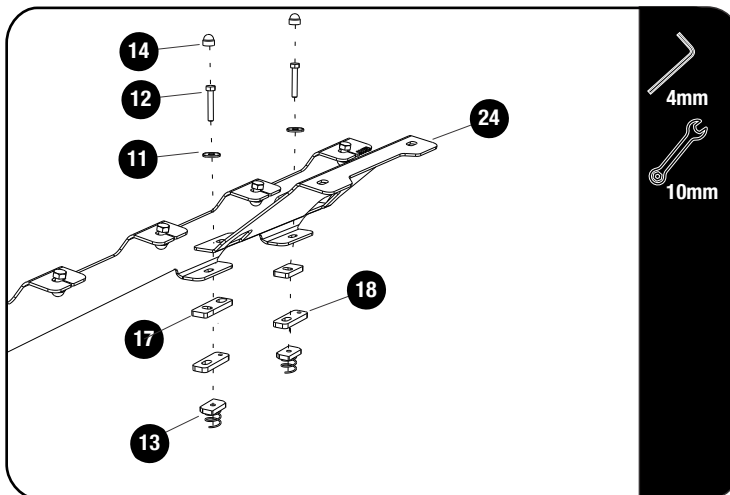

Apply a bead of silicone around each mounting hole in the roof.

Place Spacers (Item 6) over each of the mounting holes in the vehicle roof.

Place the Foot Rails onto the Spacers and secure using M6 x 35 Hex Bolts, M6 Washers and M6 Nut Plates (Items 11, 12 & 13) as shown.

Tip: straighten the wire on the Nut Plate to assist in aligning it with the Hex Bolts.

Fully tighten all the fasteners.



Tightening Torque:

M6 : 8-10Nm / 5.9 ft lb - 7.38 ft lb

3

FIT AND SECURE

3.1

Refer to RRSUNI when assembling your Slimline II Tray.



3.2



Make sure that the wind deflector is installed before you proceed to the next step.

3.3

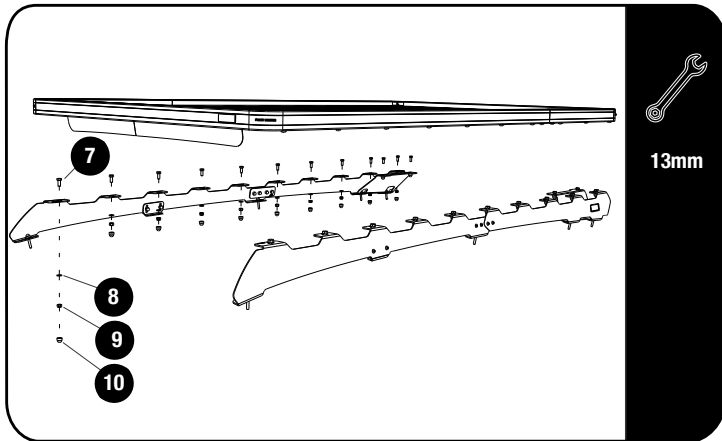

13mm



Fit your roof rack to the Foot Rails using M8 x 20 Hex Bolts, M8 x 16 x 1.6SS Flat Washers and M8 Nyloc Nuts (Items 7, 8 & 9) as shown.



Tightening Torque

M8 : 15-20Nm / 11.06 ft lb - 14.75 ft lb

3.4

Center the rack and tighten fully. Use M8 Nut Caps (Items 10) to finish off the nuts.



5

INSTALL OTHER VEHICLE AND RACK ACCESSORIES

Now's the time to visit your favorite Front Runner dealer in person or online.

IMPORTANT!

FRONT RUNNER RACK KITS OFTEN HAVE A HIGHER LOAD RATING THAN THE VEHICLES THEY ARE MOUNTED TO. PLEASE REFER TO YOUR SPECIFIC VEHICLE MANUFACTURER FOR A RECOMMENDED ROOF RATING. FRONT RUNNER CANNOT BE RESPONSIBLE FOR IMPROPER LOADING BEYOND THE VEHICLE MANUFACTURER'S STATED LOAD CAPACITY.

Be sure to tag us. We love to see our gear in action! #FrontRunnerOutfitters #BornToRoam

Share your adventures on: